

Anemone



a Little Crispy
SEWING PATTERNS



#108

Cutting

All measurements include ¼" seam allowances.

Fabric quantities are given on the back cover of this pattern.

Download and print a free coloring sheet at <https://goo.gl/HTXW0V>.

The fabrics used in the cover quilt are Essex Linen in Natural and various Kaffe Fassett shot cottons and Moda Crossweaves. I give approximate Kona cotton equivalents below.

Crib	Kona solid (approx)
A (light orange)	School Bus (brighter) or Amber (darker)
B (medium orange)	Punch (a little pinker)
C (light red)	Wine
D (dark red)	Crimson
E (green)	Bonsai
F (light blue)	Breakers
G (dark blue)	Celestial

For the crib size, you'll use one group of four colors. I suggest using a gradation (A through D) for the crib size and arrange them from A (light) to D (dark).

For the throw and queen size, there are two groups of colors (A through D, and then E through G). I suggest using two gradations: A (light) to D (dark) and E (light) to G (dark).

However, don't feel limited by what I have listed; you can use the same number of colors, or more, or fewer.

In this pattern there are a quite a few pieces to keep track of. To help you keep everything straight, the first column of the

tables are blank and all of the illustrations are in black and white, and labeled with letters (corresponding to colors). I highly recommend coloring these columns and illustrations with markers or colored pencils in your chosen fabric colors so that it is easy to keep track of what fabrics go where at a glance.

Cutting

All measurements include ¼" seam allowances.

Refer to the cutting diagrams at the end of this pattern to help you make the most efficient cuts from your fabric. Cut out your fabric as listed in the table below.

The first column in the table below is blank so that you can color it in with the fabric color you use for each letter.

Crib	4½" x 4½"	6" x 6"	4½" x 8½"
A	16	11	—
B	1	10	—
C	—	10	—
D	8	6	—
H	16	19	12

Throw	4½" x 4½"	6" x 6"	4½" x 8½"
A	20	22	—
B	4	20	—
C	4	13	—
D	21	8	—
E	4	12	—
F	—	14	—
G	16	16	—
H	28	47	20

Queen	6" x 6"	7½" x 7½"	6" x 11½"
A	20	22	—
B	4	20	—
C	4	13	—
D	21	8	—
E	4	12	—
F	—	14	—
G	16	16	—
H	28	47	20

Pictured below is a colored version of the crib quilt for reference. Refer to the cover quilt for a color version of the throw and queen quilts.

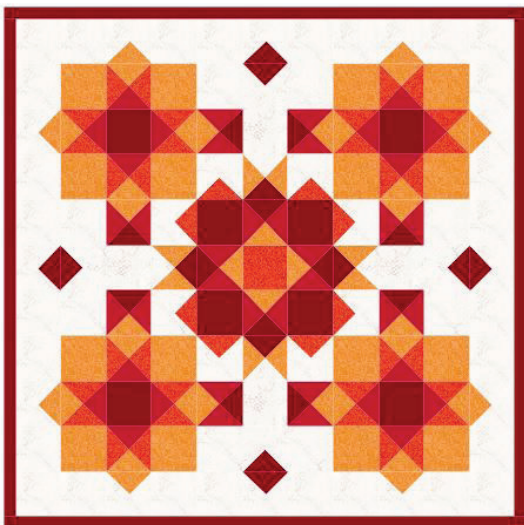

Sewing your blocks

All seam allowances are ¼". Block size is 12" finished (crib & throw) or 16½" finished (queen).

Sew your hourglass components

The first thing to do is to sew your hourglass components from half square triangles (HSTs). There is just one size of hourglass in this quilt, which is 4½" unfinished for the crib/throw, and 6" unfinished for the queen.

Make your hourglass blocks either using the following method or your own preferred method:

- Using the chart below, match up pairs of fabric with right sides together. For example, for the throw, you need 7 A+B squares, which means 7 A squares and 7 B squares matched together to make 7 pairs. I left a blank column for keeping track of colors if needed. I will explain the "Press toward" column in step 3.

Pairs	Crib	Throw/Queen	Press toward
A + B	4	7	B
A + C	3	4	C
A + D	1	4	D
A + E	—	3	E
A + H	3	4	A
B + C	4	5	C
B + H	2	8	B
C + D	3	4	D
D + H	2	—	D
H + H	6	15	H
E + F	—	6	E
E + G	—	3	E
F + G	—	8	G
G + H	—	5	G

- Draw a line diagonally across the center back of the lighter of each pair, and sew a line ¼" away from either side of the line (sewing the pair together).

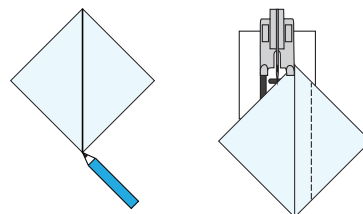

3 Cut your squares in half down the middle and press your seams toward the side listed in the table from step 1. If this creates shadowing (you can see the darker fabric through the lighter from the front), press your seams open.

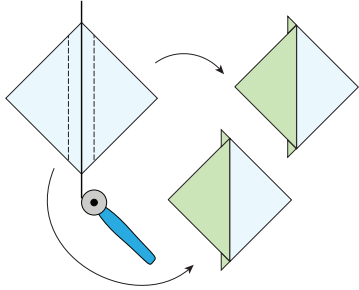

4 Align a ruler with two corners of the block and cut your HSTs in half as shown below. Note that each HST will make two mirror images.

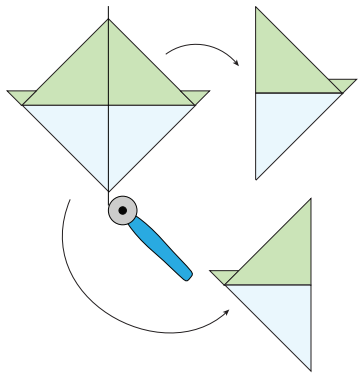

5 Color the hourglasses in the table at right for clarity. Use the table to match and sew the number of hourglass shapes from your half HSTs that are listed. Nest the seams when you sew the two halves together.

Note that the half HSTs have mirror images as illustrated below. If you mix and match the half HSTs correctly, they will form the same hourglass block when sewn together.

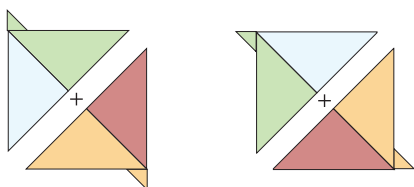

Number of blocks to make for:	Crib	Throw & Queen
-------------------------------	------	---------------

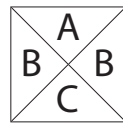

16

20

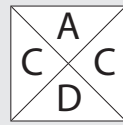

12

16

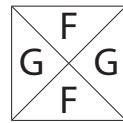

—

16

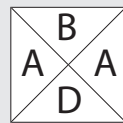

—

8



—

12

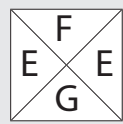

—

12

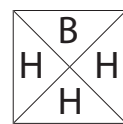

8

32



4

8

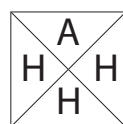

8

8

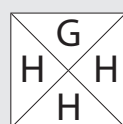

—

20

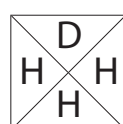

8

—

- 6** If you have been pressing to the side, on the back of your blocks, pop open the few stitches that extend beyond the cross seam (as illustrated below) and “spin” your seams to reduce bulk.

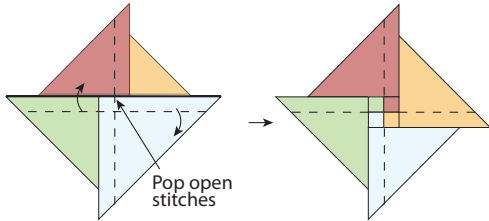

- 7** Trim your hourglass block to $4\frac{1}{2}$ " square for the crib and throw sizes (below left), or 6" for the queen size (below right). Use a ruler that has a 45 degree line to help keep the diagonal line of the block centered.

Make sure that the center point of the block stays in the very center. Do this by lining up the center point of the block with the intersection of the horizontal and vertical $2\frac{1}{4}$ " marks (crib and throw) or $3\frac{1}{4}$ " marks (queen) as illustrated below.

Trim all sides to clip off the “rabbit ears”.

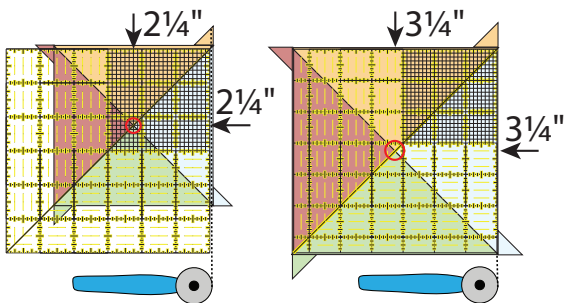

Assemble the rest of your blocks

Sew your hourglass components and plain squares into blocks that have 9 squares each. You will have some pieces left over that are part of the border you attach later. For all of these blocks, pressing direction is not as important; just try to reduce bulk as much as possible.

Again, it might help you to color in the blocks below with the colors you are using to keep things sorted out.

Assemble the rest of your blocks as follows:

Crib

- 1** Sew 4:

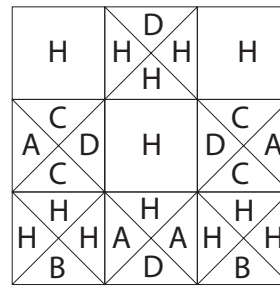

- 2** Sew 4:

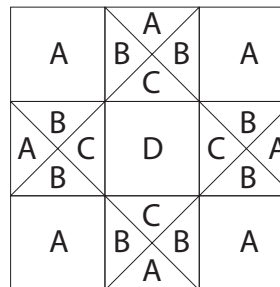

- 3** Sew 1:

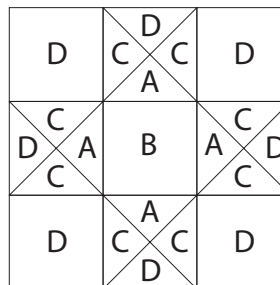

Throw & Queen

1 Sew 5:

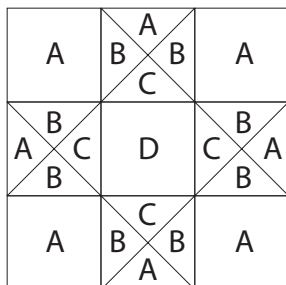

2 Sew 4:

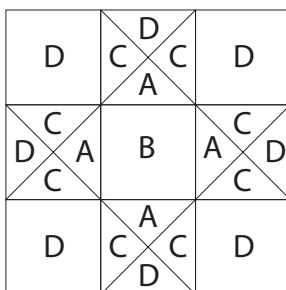

3 Sew 4:

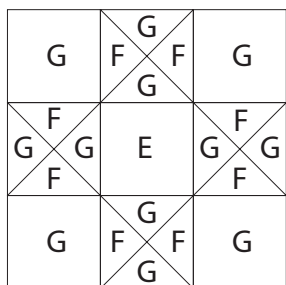

4 Sew 4:

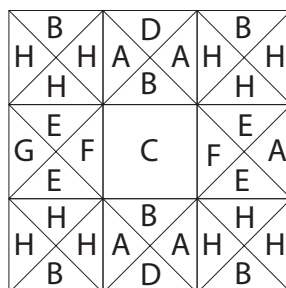

5 Sew 4:

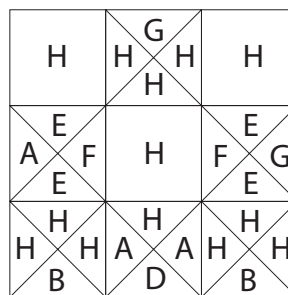

6 Sew 4, which are mirror images of the blocks from step 5:

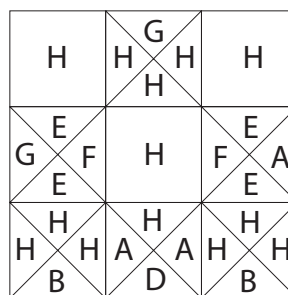

Assembling your quilt top

Sew the rest of your quilt top together following the assembly diagrams.

Quilting & finishing

When you are done the quilt top, press it well from both sides.

Layer your well-pressed quilt top with your batting and backing and baste your quilt.

Quilt, square it off so the edges are nice and straight, and then sew on your binding. Wash and enjoy!

Assembly diagram: Crib

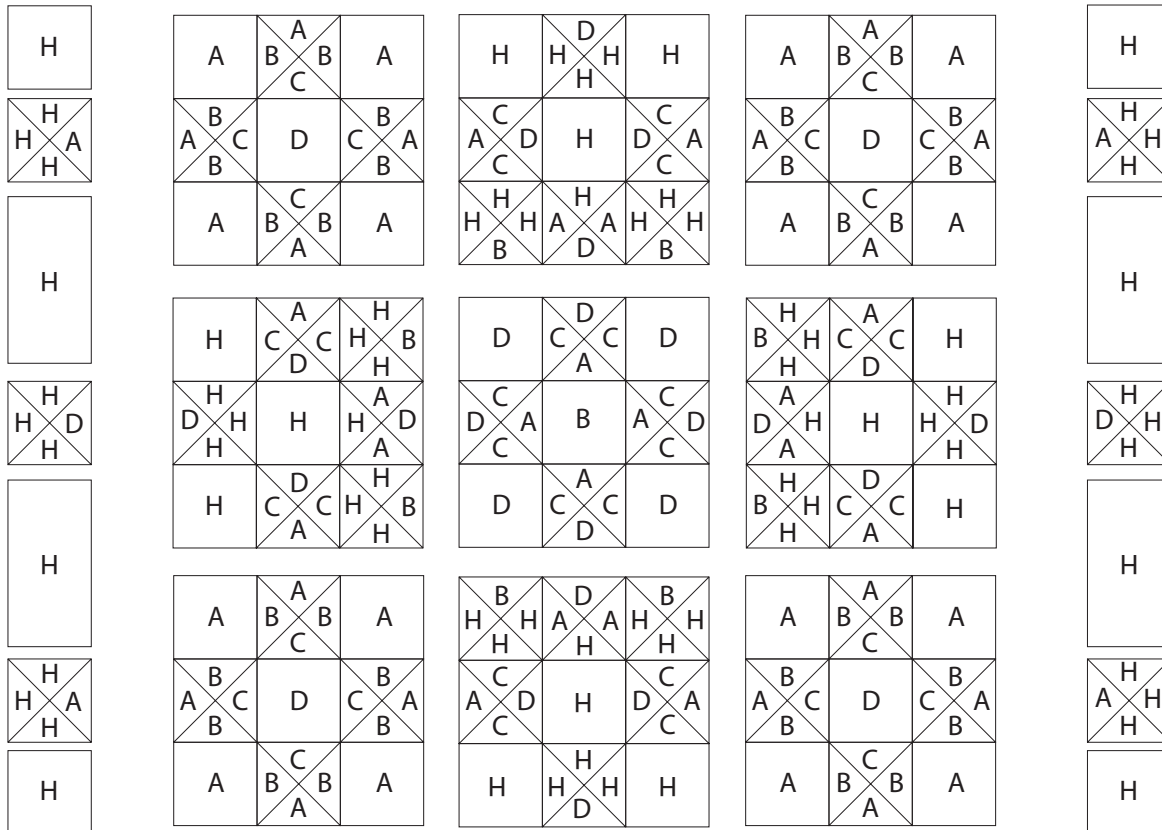
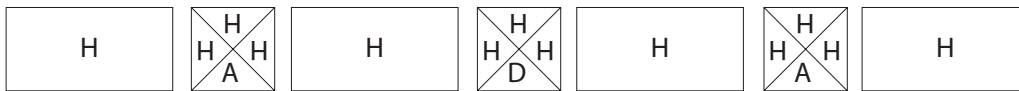

Assembly diagrams: Throw and Queen

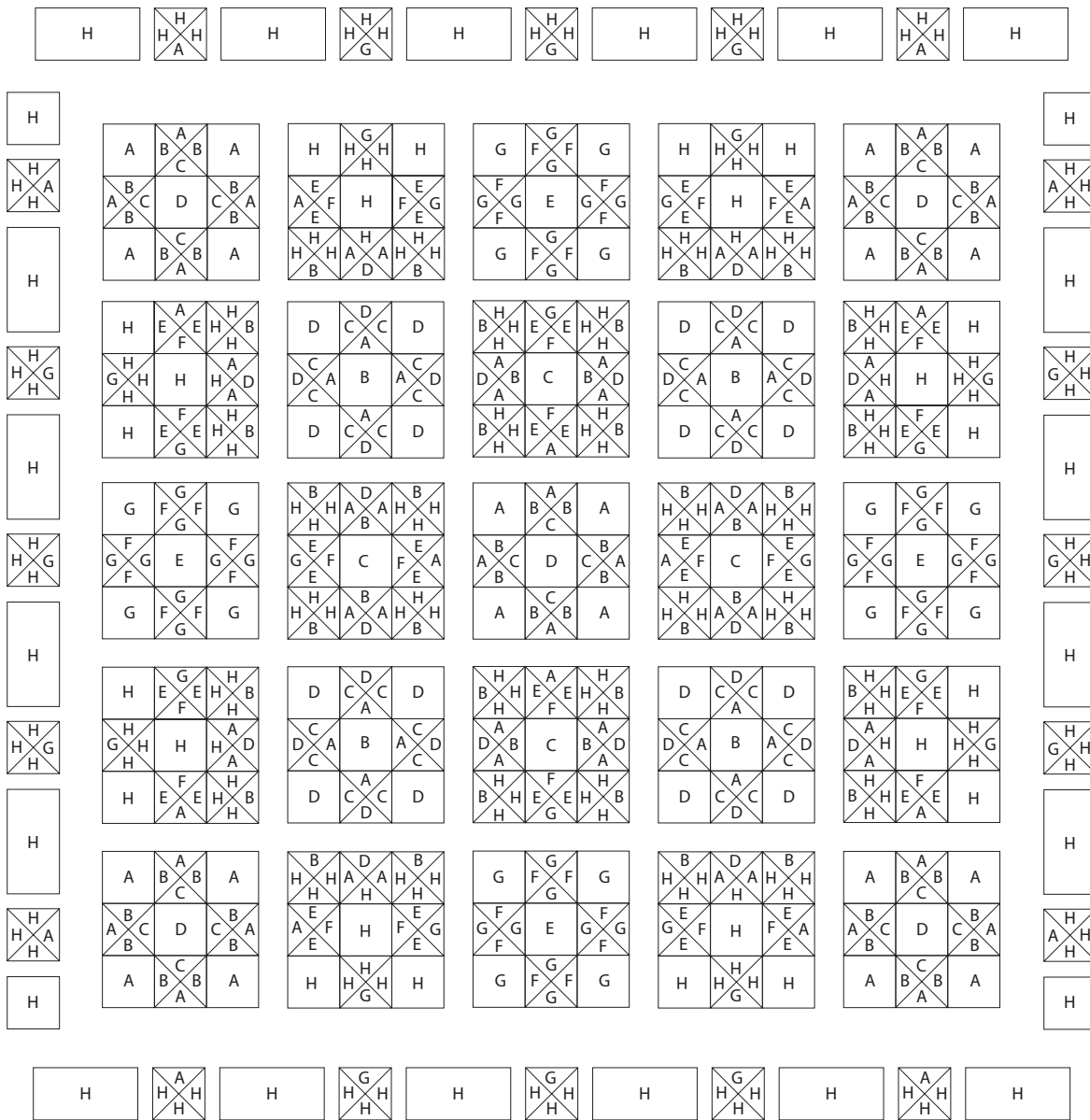

Cutting diagrams: Crib

Use the following diagrams to cut your fabric. A number and x pointing to a row means to cut that many of that row. For example: 3x means to cut three of that row.

A (Lightest)

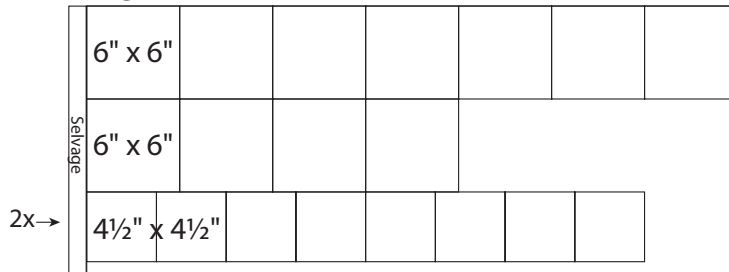

B

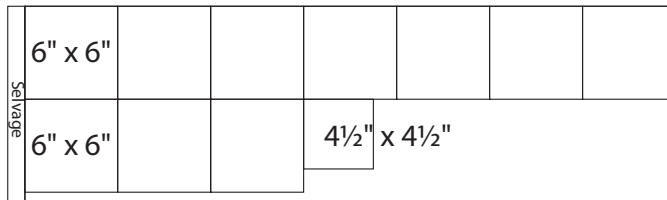

C

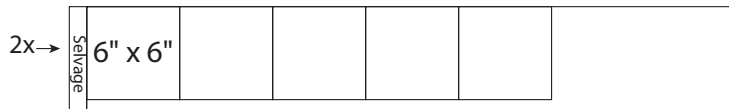

D (Darkest)

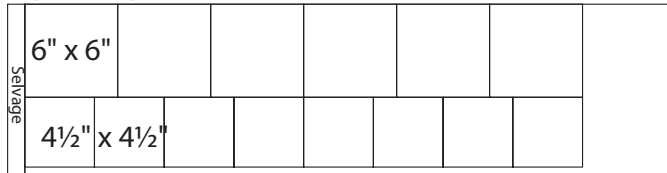

H (Background)

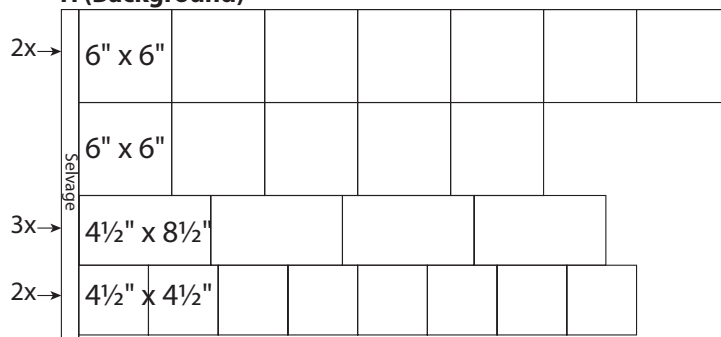

Cutting diagrams: Throw

Use the following diagrams to cut your fabric. A number and x pointing to a row means to cut that many of that row. For example: 3x means to cut three of that row.

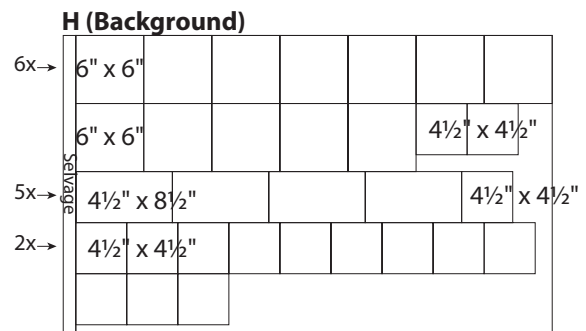
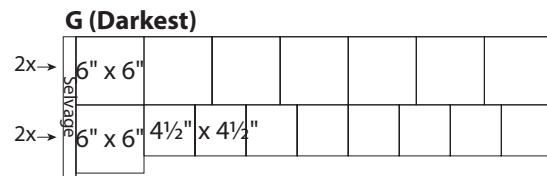
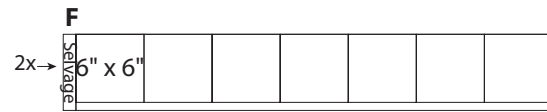
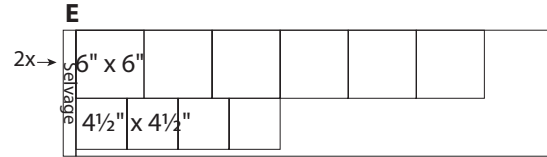
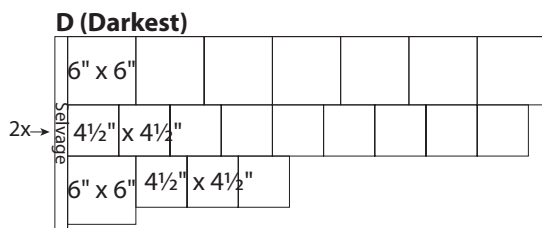
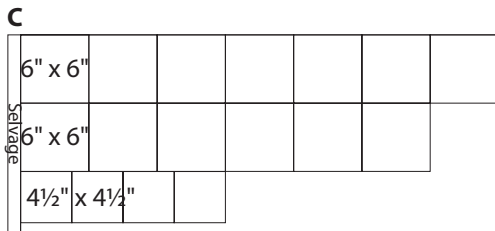
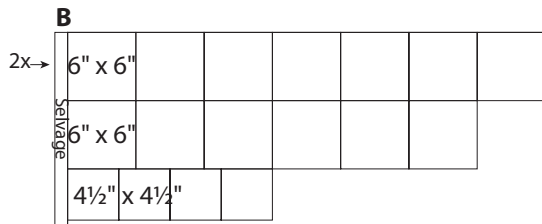
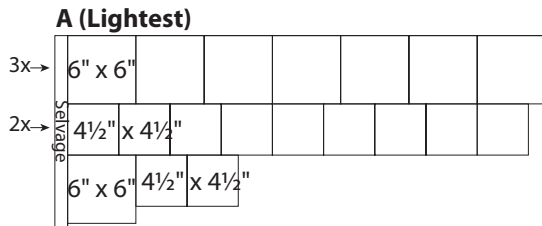

Cutting diagrams: Queen

Use the following diagrams to cut your fabric. A number and x pointing to a row means to cut that many of that row. For example: 3x means to cut three of that row.

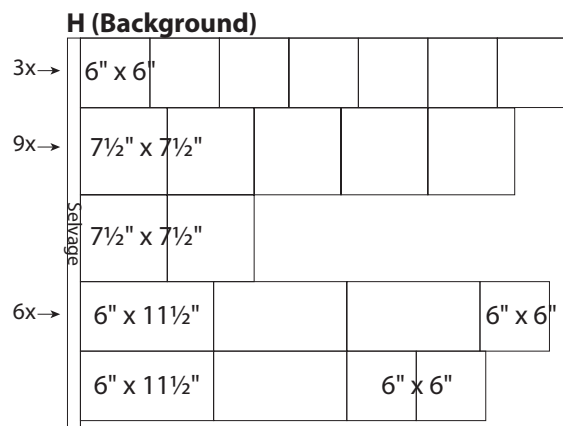
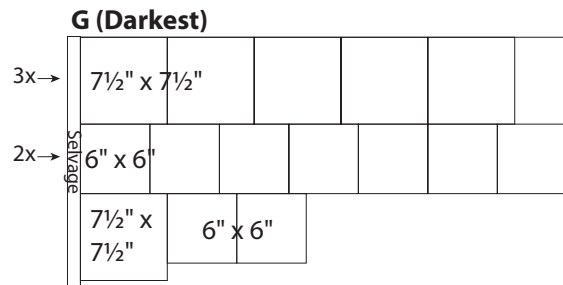
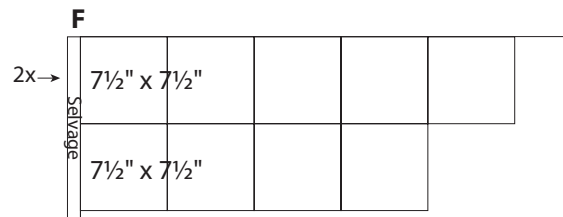
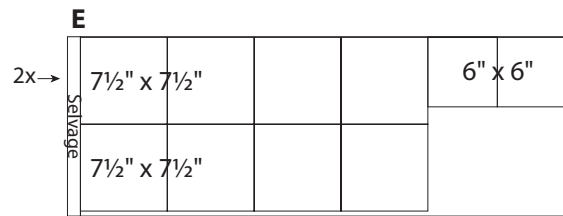
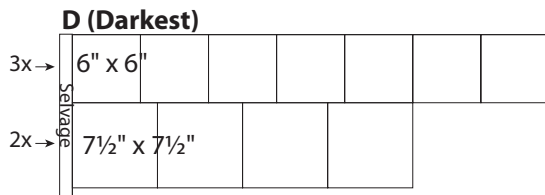
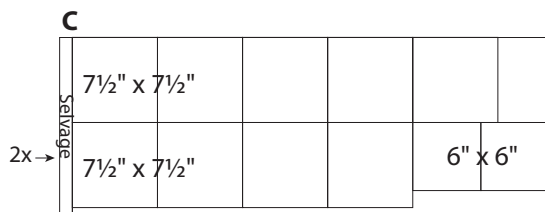
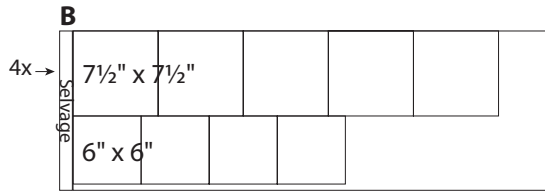
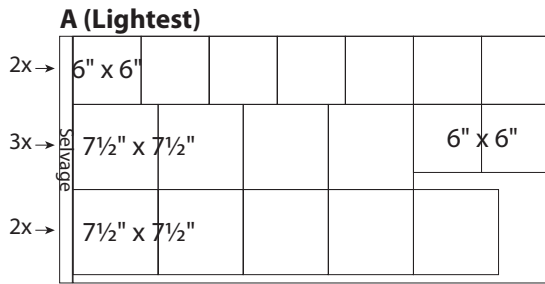



Anemone

Cover quilt is approximately 68" x 68".

Quilt designed, pieced, and quilted by Kristin Lawson.

Copyright ©2014 by Kristin Lawson of a Little Crispy. All rights reserved. No part of this pattern may be copied or shared in any form without prior written consent.

This very colorful quilt only has 7 colors and a background. Pick some favorite solids or prints and make your own flower garden! Simple shapes and easy piecing make this quilt easier than it looks!

Check out my latest patterns and other info at alittlecrispy.com, or follow what I'm up to on Instagram [@CrispyKristin](https://www.instagram.com/CrispyKristin). For questions or comments, please contact me at kristin@alittlecrispy.com.

Fabric

You will need a variety of 100% cotton quilting fabrics, 42" wide, as listed in the table below. I recommend purchasing slightly more than listed just in case. Choose a solid or a non-busy print for your background for contrast.

	Crib/Toddler	Throw	Queen
Finished size	44" x 44"	68" x 68"	94" x 94"
Red/orange gradation*			
A (lightest)	5/8 yard	1 yard	1½ yards
B	3/8 yard	2/3 yard	1 1/8 yards
C	3/8 yard	1/2 yard	2/3 yard
D (darkest)	1/3 yard	5/8 yard	1 yard
Blue/green gradation*			
E (lightest/green)	—	1/2 yard	2/3 yard
F	—	3/8 yard	2/3 yard
G (darkest)	—	3/4 yard	1 1/4 yards
Other fabrics			
H (Background)	1 1/4 yards	2 1/4 yards	3 7/8 yard
Binding**	1/2 yard	2/3 yard	3/4 yard
Backing	2 3/4 yards	4 yards	8 1/2 yards
Batting	48" x 48"	72" x 72"	98" x 98"

*Refer to inside the pattern for more info on color selection.

**Binding amount assumes 2½" strips, cut the width of the fabric. You'll need more if you cut on the bias.



a little Crispy
SEWING PATTERNS



ALC-108

